



JXDH-6002 II DVB Demodulator Decoder

User Manual

V2.0

ChengDu Jiexun Electronics Co., Ltd

contents

1. SAFETY	1
2. OVERVIEW	1
2.1 Features.....	2
2.2 Factory Options	2
3. INSTALLATION	3
3.1 Inspection and Test	4
3.2 Functional Self Test.....	4
4. FRONT PANEL	4
4.1 Front Panel List	4
4.2 Indicator LEDs	4
4.3 Liquid Crystal Display	5
4.4 Keypad	5
4.5 Common Interface	5
5. REAR PANEL	6
5.1 Power Supply	6
5.2 Output Connectors	6
5.3 ASI Input Connector	7
5.4 RS-232 Interface	7
5.5 Ethernet Interface.....	7
5.6 TS/IP Interface (Factory Optional)	7
6. Function Block Diagram	7
7. START TO USE	8
7.1 Main Menu.....	8
7.2 Inputs	9
7.2.1 Status.....	9
7.2.2 QPSK/COFDM/QAM/DVB-S2.....	9
7.2.3 Ethernet	10
7.3 Outputs	11
7.3.1 Status.....	12
7.3.2 CI	12
7.3.3 Decoder	12
7.3.4 ASI.....	13

7.3.5 ASI2/SDI.....	14
7.3.6 Mux / Filter.....	14
7.3.7 Ethernet.....	16
7.4 System.....	18
7.4.1 Local Setup.....	19
7.4.2 Trap IP Addr.....	19
7.4.3 Unit Name.....	19
7.4.4 Properties.....	19
7.4.5 Factory Settings.....	20
7.4.6 Optional Function.....	20
7.4.7 Setting Machine Type.....	20
8. FAQ.....	20
9. Appendix.....	21
9.1 Accessory List.....	21
9.2 Specification.....	21

1. SAFETY

Please read this chapter before installation and use of the device

This equipment is provided with a protective earthing ground incorporated in the power cord. The main plug shall only be inserted in a socket outlet provided with a protective earth contact. Any interruption of the protective conductor, inside or outside the device, is likely to make the device dangerous.

The device described in this manual is designed to be used by properly-trained personnel only. Adjustment, maintenance and repair of the device shall be carried out by qualified personnel.

No operator serviceable parts inside. Refer servicing to qualified personnel. To prevent electrical shock, do not remove covers.

For the correct and safe use of the device, it is essential that both operating and servicing personnel follow generally accepted safety procedures in addition to the safety precautions specified in this manual.

Whenever it is likely that safety protection is impaired, the device must be made in-operative and secured against unintended operation. The appropriate servicing authority must be informed. For example, safety is likely to be impaired if the device fails to perform the intended measurements or shows visible damage.

WARNINGS

- I Do not use the equipment in moisture environment surroundings.
Avoid direct contact with water.
- I Never place the equipment in direct sunlight.
- I The outside of the equipment may be cleaned using a lightly dampened cloth. Do not use any cleaning liquids containing alcohol, methylated spirit or ammonia etc.
- I For continued protection against fire hazard, replace line fused only with same type.

2. OVERVIEW

JXDH-6002 II-X is a professional IRD with a variety of input (including DVB over ASI, IP, QPSK, QAM, COFDM and DS3) and output (CVBS, SDI, ASI, DS3 and IP) combinations. An appropriate IP port equipped as an option supports DVB over IP applications. LAN control and monitoring are achieved with TCP/IP, SNMP and HDMS*.

(*Headend Devices Management System, a remote management software)

2.1 Features

- I Fully complies with MPEG-2, MP@ML and DVB-S/-T/-C standards
- I IP input or output with UDP/RTP (optional)
- I Multicast and Unicast on IP
- I Supports PAL, NTSC or SECAM
- I Supports various Conditional Access systems
- I SDI video output with digital audio embedded
- I Two sets of independent ASI outputs
- I Automatic PMT update
- I Compatible with Multiple De-encrypt CI modules
- I DS3 I/O for TS (optional)
- I Switchable audio sound track
- I Teletext VBI, EBU subtitle and DVB subtitle
- I Upgradeable through LAN
- I Easy-to-use LCD menu

2.2 Factory Options

Model No. Function	JXDH-6002 II					JXDH-6002 II 7					JXDH-6002 II 8				
	-S	-C	-T	-D	-S2	-S	-C	-T	-D	-S2	-S	-C	-T	-D	-S2
IP Output (TS)											✓	✓	✓	✓	✓
IP Input (TS)						✓	✓	✓	✓	✓					
DS3 Input/Loop through				✓					✓					✓	
DVB-S Input	✓					✓					✓				
DVB-S2 Input					✓					✓					✓
DVB-C Input		✓					✓					✓			
DVB-T Input			✓					✓					✓		
PCMCIA Slot								✓							
ASI TS Input / Output								✓							
Audio Embedded SDI Output								✓							
Ethernet Remote Control								✓							
BNC Video Output								✓							
A/V Output								✓							
Balance XRL Audio Output								✓							
Simulcrypt Compliant								✓							
✓ Standard															

Table 2.1 Factory Option list of JXDH-6002 II -X series

The '✓' sign indicates standard option.

3. INSTALLATION

Warning

This equipment is provided with a protective earthing ground incorporated in the power cord. The main plug shall only be inserted in a socket outlet provided with a protective earth contact. Any interruption of the protective conductor, inside or outside the instrument, is likely to make the instrument dangerous. The type of main plugged shipped with each instrument depends on the country of application.

The mounting environment should be relatively dust free, free of excessive vibration and the ambient temperature between 0 °C to 40 °C. Relative humidity of 20% to 80% (non-condensed) is recommended.

Air intake for cooling is achieved via holes at the side of the device and the fans inside. The air flow should not be obstructed. Therefore, the device has to be placed on a flat surface, leaving some space at the sides of the device.

When in operation, the internal temperature should not exceed the limit of 70 °C.

Caution

Do not connect AC power until you have verified that the line voltage is correct and the proper fuses are installed. The equipment requires a power source of either 50/60 Hz at 110V or 50/60 Hz at 240V. The voltage ranges for these nominal voltage values are shown in the table:

POWER REQUIREMENT	
Input voltage	90-260 Vrms auto select
Frequency	47 to 63 Hz
Power	50 VA max. / 30 VA typical.
Current	110 V/0.27A or 240 V/0.125A typical

Table 3.1 Power requirement

Caution

Be sure the supply voltage is within the specified range.

Checking the fuses

The recognized recommended fuses are size 5 by 20 mm, rate T 2.0A, 250 V (UL and IEC approved).

The line fuse is housed in a small container besides the power connector on the rear panel. To check the fuse, insert the tip of a screwdriver in the slot at the middle of the container and pry gently to extend the fuse where there is a little tap and pull out the fuse gently. The fuse is attached to the line module and cannot be removed.

3.1 Inspection and Test

Check if the device has any visible damage. If everything seems all right, power can be applied to the device. The main socket and fuse are located at the rear panel of the device.

When the device is turned on, verify that the display shows the following message:

Digital TV Processor (factory default unit-name)
IP: 168.192.1.21 (factory default IP Address)

If no message is shown in the display or there is not light in the display, the device is defective and has to be returned for servicing.

3.2 Functional Self Test

No specific functional self test is needed.

The device has been factory tested according to recognized test procedures and is ready for operation.

4. FRONT PANEL

4.1 Front Panel List

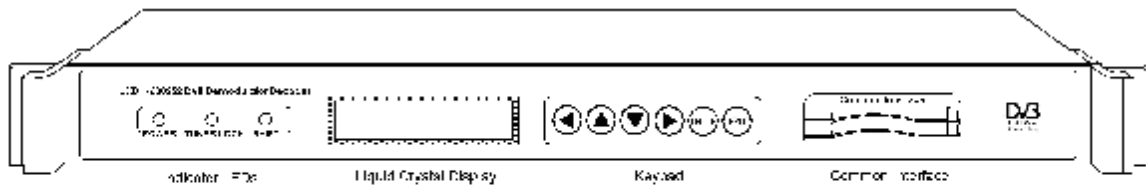

Figure 4.1 Front Panel of JXDH-6002 II -X Series Receiver

4.2 Indicator LEDs

There are 3 LED-indicators:

-POWER: the status of the power supply

green: the power is turned on
off : the power is turned off

-TUNER LOCK: the status of the tuner

green: the incoming QPSK is locked by the tuner.
off : there is no QPSK input signal or the signal is unlocked

-**ALARM**: the status of input signal source, which includes IP input, QPSK signal input and DVB-ASI TS input.

4.3 Liquid Crystal Display

The 2 x 20 character Liquid Crystal Display (LCD) shows all the required information about the selected parameters.

The top row of the LCD shows the selected parameter. The bottom row indicates the present values and how these can be adjusted.

The parameters are grouped in three menus:

- the **Inputs**, which gives the full operation on inputs parameters
- the **Outputs**, with the full operation control functions on outputs parameters
- the **Systems**, gives the general device management parameters and informs about the device working status

When the label '->' is showed in the right side on the second row, it indicates you can use **<ENTER>-key** for further navigation in sub-menus.

4.4 Keypad



Figure 4.2 Keypad of JXDH-6002 II -X series

The 6 keys on the front panel allow you to navigate in the information given on the LCD and to change parameters, when the device operates under local control.

The **<ENTER>-key** is used to enter the main menu or a sub-menu. When you stand on the preferred menu, **<ENTER>** is used to active the parameter on the bottom line and allows you to change the value. It also finishes the input of new alphanumeric values and confirms the changes.

The **<▲>-and<▼>-keys** are used to select between the main menus or sub-menus or programs. When you stand on the preferred menu and the parameter is active, they are also used to change the numerical values. Selecting a digit with the **<◀>-and <▶>-keys**.

The **<EXIT>-key**, is used to exit a menu without any action.

4.5 Common Interface

There are two Common Interface slots. You can insert up to two different CAM modules for descrambling.

5. REAR PANEL

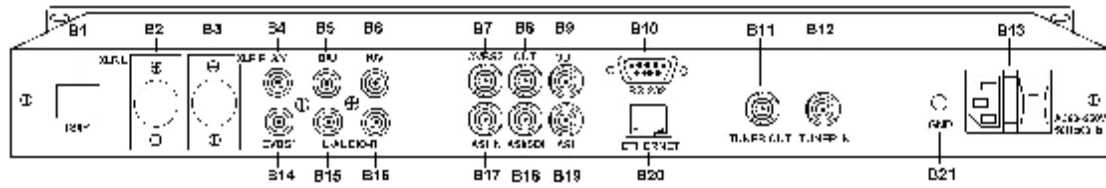

Figure 5.1 Rear Panel of JXDH-6002 II-X Series

B1	TS/IP Input/Output interface
B2	XRL L interface
B3	XRL R interface
B4	RGB/YUV interface (G/Y)
B5	RGB/YUV interface (B/U)
B6	RGB/YUV interface (R/Y)
B7	CVBS2 Output interface
B8, B18	ASI2/SDI output interface
B9, B19	ASI1 output interface
B17	ASI input interface
B10	RS-232 interface
B11	Tuner Loop Out interface
B12	Tuner In interface
B13	Power socket, AC 90~260V
B14	CVBS1 Output interface
B15, B16	L-Audio-R interface
B20	Ethernet interface for remote management system
B21	Grounding

5.1 Power Supply

The power cord is inserted to an IEC main socket at the side of the device.

Check that the power cord is suitable for the country where the device will be used.

A standard power cord with a European DIN 49441 two pin main plug is delivered together with the device.

The line fuses are housed in a small container at the side of the power supply connector.

5.2 Output Connectors

The ASI interface B9), B19) and ASI2 interface B8), B18) are two pairs of independent ASI output. Both use female BNC connectors, with 75 Ohm impedance. The ASI interface B18) and B19) are used as a redundant output of B8) and B9) out.

Note: the B8), B18) interface could be configured as SDI with Audio embedded. Please refer to **Chapter 7.3.5**.

5.3 ASI Input Connector

The ASI input B17) is a 75 ohm female BNC connector.

5.4 RS-232 Interface

This interface is a 9-pins female sub-D connector. The RS-232 interface is only used for factory software upgrade and configuration, so you are not allowed to connect any cable to the RS-232 connector, as that could damage the device.

5.5 Ethernet Interface

An RJ-45 connector B20) provides a remote control interface.

5.6 TS/IP Interface (Factory Optional)

An RJ-45 connector B1) provides a transport stream over IP input or output.

6. Function Block Diagram

The chart below shows the complete function block of JXDH-6002 II -X. Where the arrow 'à' or 'dotted arrow' indicates the transport stream flow. The function blocks embayed in the dotted line are user-configurable.

The TS/IP function block is valid when the TS/IP streaming board is installed into the JXDH-6002 II -X. You can set it as 'IP In' or 'IP Out', which is exclusive to each other (refer to section 7.4.6).

The Mux/Filter function block is standard option and could be configured as internal 2-way 'multiplexer' or 'filter', which is exclusive to each other. Also you can turn on or turn off the block (refer to section 7.4.6).

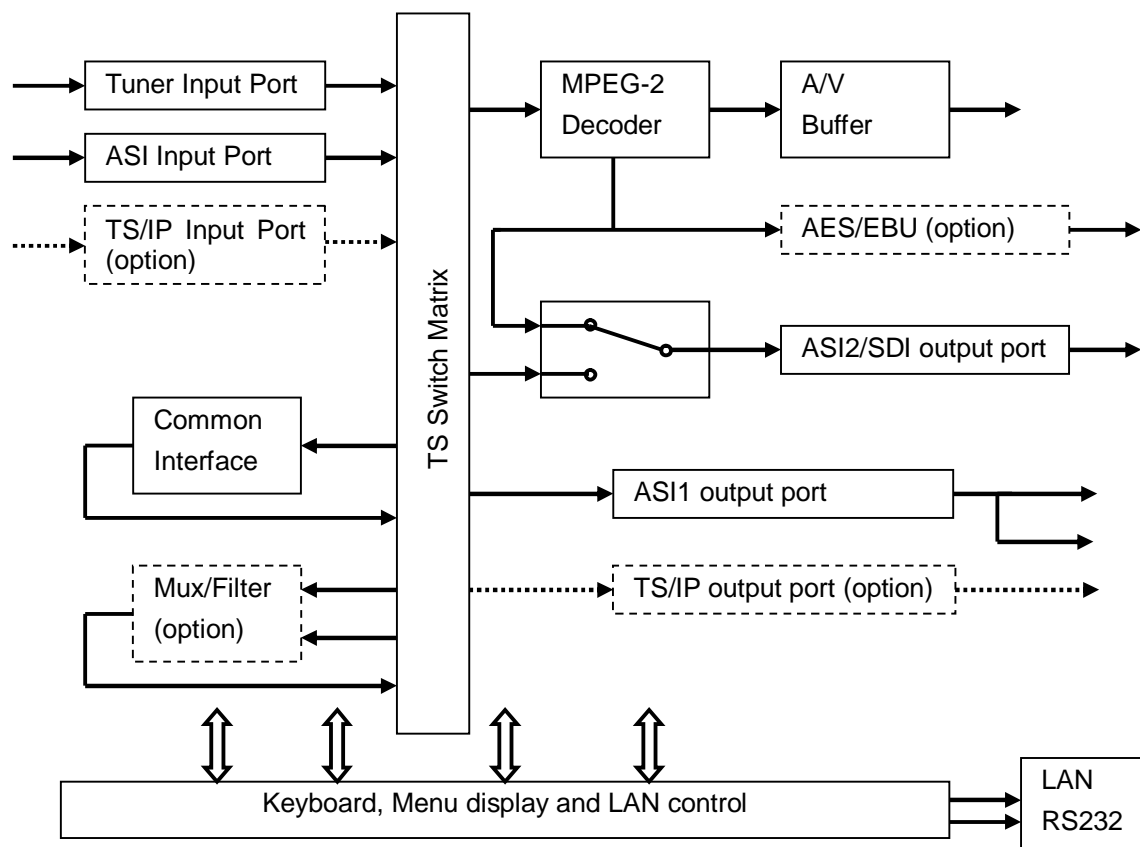

Figure 6.1 JXDH-6002 II-X Function Block Diagram

7. START TO USE

The device allows you to configure, control and monitor through the Keypad and front panel display when a remote control system is not used.

7.1 Main Menu

Turn on the device and wait for 8 to 10 seconds, while the device will complete self inspection and configuration. The top row of the LCD shows the name of the device. The local IP address is displayed on the bottom row of the LCD.

Note: the local IP address and unit name can be changed in the System Menu (refer to section 7.4.1 and 7.4.3 System).

Use the <ENTER>-key to enter on the Main Menu. The <▲>-and<▼>-keys are used to choose between the three main menus.

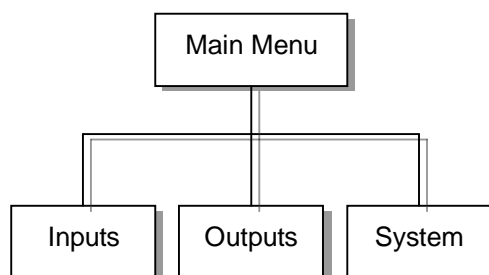

Figure 7.1 Main Menu Structure

7.2 Inputs

Under Inputs Menu, you can monitor and configure the parameters of the Tuner, and TS over IP input (only when the TS/IP streaming board is installed and the board is set to "IP In", refer to section 7.4.6 Optional Function)

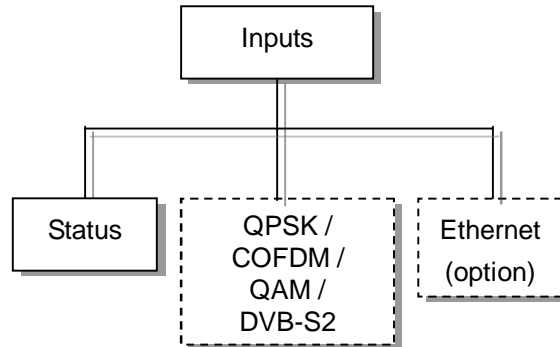

Figure 7.2 Inputs Menu Structure

7.2.1 Status

You can monitor the status of the inputs signals under the status menu.

- **ASI Input:** locked or unlock indicate the status of the ASI input.
- **Tuner Input:** when the QPSK/QAM/COFDM signal is locked by the tuner, the bit rate is displayed on the bottom row of LCD.
- **Ethernet:** this indicates the status of the transport stream over IP input. The bitrate is displayed on the bottom row of the LCD, if IP input is valid (note this menu is showed only when the TS/IP streaming board is installed and the board is set to "IP In", refer to section 7.4.6 Optional Function).

7.2.2 QPSK/COFDM/QAM/DVB-S2

The tuner setting menu is different and exclusive according to DVB-S/DVB-T/DVB-C/DVB-S2 tuner is equipped. To receive the QPSK/COFDM/QAM/DVB-S2 signal, the relative parameters below must be set to appropriate values for the receiving antenna over which the device can receive the signal.

QPSK

- **LNB Local Oscillator (L.O.) Freq:** enter the frequency of the LNB in MHz.
- **Satellite Freq:** edit the satellite down link frequency in MHz. The IF frequency will be calculated automatically.
- **Symbol Rate:** enter the QPSK symbol rate.
- **LNB Voltage:** select the correct LNB voltage output of the F-connector: Off, 13 V, 18 V. <A>
- **LNB 22KHz:** activate the LNB 22 kHz control signal to the LNB: On or Off.

Note: please contact the local satellite operator for the satellite frequency and symbol rate.

<A> Normally, 13V switches the LNB to receive Vertical/Left hand polarization while 18V receive Horizontal/Right hand.

 Normally, 22KHz control signal switches the LNB to receive high band if any.

COFDM

- **Frequency:** enter the proper frequency of the COFDM signal in MHz.

QAM

- **Constellation:** enter the modulation mode of the QAM signal.

- **Frequency:** enter the frequency of the QAM signal in MHz.

- **Symbol Rate:** edit the symbol rate to the proper value in KBaud.

DVB-S2

- **LNB Local Oscillator (L.O.) Freq:** enter the frequency of LNB in MHz.

- **Satellite Freq:** edit the satellite down link frequency in MHz. The IF frequency will be calculated automatically.

- **Symbol Rate:** enter the QPSK/8PSK symbol rate.

- **LNB Voltage:** select the correct LNB voltage output of the F-connector: Off, 13 V, 18 V. <A>

- **LNB 22KHz:** activate the LNB 22 kHz control signal to the LNB: On or Off.

Note: please contact the local satellite operator for the satellite frequency and symbol rate.

<A> Normally, 13V switches the LNB to receive Vertical/Left hand polarization while 18V receive Horizontal/Right hand.

 Normally, 22KHz control signal switches the LNB to receive high band if any.

- **Demodulation Mode:** select the DVB-S or DVB-S2 demodulation mode.

- **Operation Mode:** select the appropriate operation mode in the menu. There are QPSK 1/2, 2/3, 3/4, 4/5, 5/6, 8/9, 9/10 and 8PSK 2/3, 3/4, 3/5, 5/6, 8/9, 9/10 to choose among.

- **Pilot:** select Off or On according to the actual signal.

- **Roll-Off Factor:** you can choose 0.2, 0.25 or 0.35.

7.2.3 Ethernet

(Note this menu is showed only when the TS/IP streaming board is installed and the board is set to "IP In", refer to section 7.4.6 Optional Function)

The Ethernet connector is for receiving transport stream over IP. The Ethernet connector has

user-configurable IP address, network mask and default gateway. These must be set to appropriate values for the network over which the transport stream over IP is received.

- **Stream IP Addr:** Enter the IP address for streaming IP input of the unit.
- **Stream Network:** Enter the network sub mask for the subnet to which the unit is connected for IP streaming traffic.
- **Stream Gateway:** Set the gateway for the network to which the unit is connected for IP streaming traffic.
- **Stream Mac Address:** factory-set MAC addresses are guaranteed to be unique. Therefore you cannot configure the address.
- **Multicast IP Addr:** Enter the IP address of the multicast stream for the transport stream over IP.
- **Multicast UDP Port:** Enter the UDP port number of the TS over IP stream.
- **Protocol:** select the protocol for multicast: UDP or RTP.
- **Output Smoothing:** set the quality of TS which comes from the TS/IP input.
 - Auto:** the bit rate is variable.
 - Disable:** the unit let the TS pass by.
 - Fixed Rate:** the bitrate is fixed.
- **TS Bit Rate:** set the bit rate of the TS comes from the TS/IP input. The setting is only valid when the output smoothing is configured as Fixed Rate.

7.3 Outputs

Under Outputs Menu, you can monitor and configure the parameters of the CI, AV decoder, ASI out, ASI2/SDI out, Mux/Filter (A), and TS over IP output (B).

(A) The Mux/Filter menu is showed only if the functional block is enabled. Refer to section 7.4.6.

(B) The menu is showed only if the IP streaming in/out board is installed and the TS/IP streaming board is set to "IP Out". Refer to section 7.4.6.

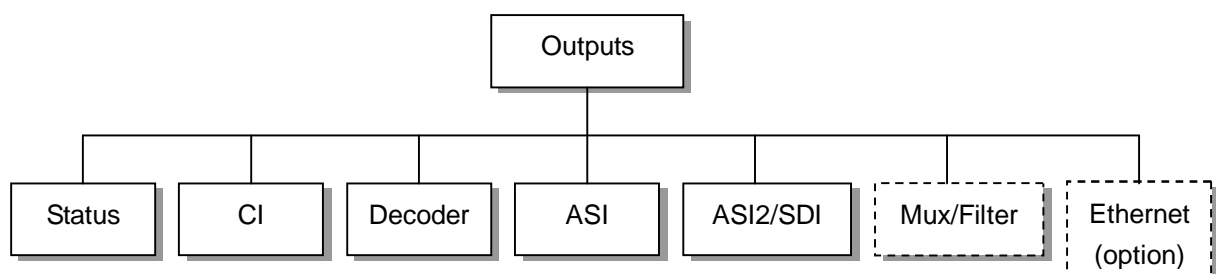

Figure 7.3 Outputs Menu Structure

7.3.1 Status

There are 3 displays on the LCD for monitoring the status of the decoder, the common interface.

- **Decoder:** OK or Alarms indicates the status of the decoder. You can use the **<ENTER>-key** to check detailed information in the submenu of the Decoder.

- **CI:** You can check the information of the CAM Modules in Slot1 and Slot2.

7.3.2 CI

There are two PCMCIA slots for inserting CAM for de-encrypting program from the input signal.

Before setting CI, ensure the signal from ASI input is locked or the Tuner locks on the correct Transponder (this depends on in which signal the encrypted program carried). The 'Tuner Lock' LED will 'on' in green.

There are 2 submenus: 'CI Source' and 'Setup' which allow you to set or select the parameters of the CI.

- **CI Source:** press the **<ENTER>-key**, then use **<▲>** or **<▼>-key** select Tuner or ASI input or TS/IP input (only when the TS/IP is set "IP In", refer section 7.4.6 for details) to set the signal source of descrambling, press **<ENTER>-key** to save or press **<EXIT>-key** to scrap.

- **Setup:** under this sub menu, you can see all program names from the source of CI that was set in 'CI Source' previously. All free programs are marked with 'Free' in the first row.

To select which program to be de-encrypted, press the **<▲>** or **<▼>-key** to roll up and down the program names and press **<ENTER>-key** to change the status of the corresponding program (only encrypted program could be selected). Three different statuses could be set:

Slot 1 (de-encrypted with upper CAM inserted)

Slot 2 (de-encrypted with lower CAM inserted)

Bypass (no de-encryption).

The status will be shown in the first row on the LCD display. Confirm this setup when leaving this sub menu, press **<ENTER>-key** to save or press **<EXIT>-key** to scrap.

The de-encrypted program could be delivered to other functional blocks, like A/V decoder, ASI, ASI2/SDI, Mux/Filter and TS/IP output (refer to section 7.3.3~7.3.6 for more).

7.3.3 Decoder

You can configure the parameters of Video and Audio of the program decoded by AV decoder.

- **Program:** under this sub menu, you will see all program names detected by 4000P. The programs could be coming from ASI input, Tuner, TS/IP input or the internal CI de-encryption block. Use the **<▲>** or **<▼>-key** to roll up or down between the program names, and use

<◀>-and <▶>-key to switch among input sources, where a number in front of the program name indicates the input source:

0-xxxxx displays the program name, which comes from ASI input.

1-xxxxx displays the program name, which comes from TUNER input.

2-xxxxx displays the program name, which comes from TS/IP input

3-xxxxx displays the program name which comes from the CI.

A few seconds after the program being selected, the A/V signal will be delivered to the related connectors on the back panel.

- **Video:** You can configure the video parameters of programs in this submenu. Press the **<ENTER>-key** to confirm or press the **<EXIT>-key** to cancel.

Video Standard: you can select Auto or SECAM or NTSC or PAL for the composite video output.

Screen: select the screen mode: 4:3 Full, 16:9 Full or 4:3 Letterbox.

DVB Subtitle Lang: select the language of DVB Subtitle.

EBU Subtitle Lang: select the language of EBU Subtitle.

Subtitle Priority: configure the priority of Subtitle; choose whether DVB or EBU should be first.

- **Audio:** You can configure the audio settings in the submenu.

Audio Level: use the **<▲> <▼> <◀> <▶>-keys** to modify the audio level within this range: 0~99.

Audio Mode: select Stereo, Left, Right or Mono for soundtracks.

Audio Language: select the language of the audio.

7.3.4 ASI

You can configure the settings of ASI in this menu.

- **ASI Source:** Press the **<ENTER>-key** and use the **<▲> or <▼>-key** to roll up or down to select the signal source of ASI output, there are 4 type of signal source optional:

CI De-encrypted: the de-encrypted transport stream from CI functional block will be delivered to the ASI output port on the back panel.

TUNER: the transport stream from Tuner block will be delivered to the ASI output port on the back panel.

ASI Input: the transport stream comes from ASI input port will be delivered to the

ASI output port on the back panel.

Mux TS: the transport stream comes from internal Mux / Filter functional block will be delivered to the ASI output port on the back panel.

(The Mux TS is valid only when the Mux/Filter function block is enabled and turned on. The Mux TS indicates not only the after-multiplexed TS when Mux is enabled, but also the after-filtered TS when the filter is enabled, refer to section 7.3.6 and section 7.4.6 for how to set the Mux / Filter function block.)

Press **<ENTER>-key** to save or press **<EXIT>-key** to scrap. A few seconds after the source being selected, the TS will be delivered to the ASI output port on the back panel.

- **ASI Package Length:** you can configure the package length of ASI output as 188 bytes or select Bypass.

7.3.5 ASI2/SDI

The ASI2/SDI port is user-configured as ASI output or SDI output.

If the port is configured as ASI2, the configuration method is the same as ASI (refer to the section 7.3.4).

If the port is configured as SDI, there are two parameters which need to be set: 'Audio PID' and 'Embed Audios'.

- **Audio PID:** press the **<▲> <▼>-keys** to choose the audio PID from 1~4.

- **Embed Audios:** there are 4 options: none, one&two, two, and one.

7.3.6 Mux / Filter

Note this Mux or Filter menu is showed only when the Mux/Filter function block is enabled and turned on. And the Mux / Filter are alternative (refer to section 7.4.6 for how to turn on and set the Mux / Filter function block).

Be sure the s/w supports Mux / Filter function. The earlier s/w has masked the Mux / Filter function. After s/w: 03.9a.xx, this Mux / Filter function has been unmasked.

Mux

Mux Switch: the internal multiplexer could be switched On/Off. The default value is 'off'. To activate the re-Multiplexing function, you should turn on this Mux functional block.

Bit Rate: should be set to a specified value that doesn't exceed the Maximum physical limit of the output medium. For example, to deliver the multiplexed TS to an 8MHz DVB 256QAM modulator, it should not exceed 55000Kb/s, otherwise overflow occurs.

TS ID: you can configure the TS ID to mark the multiplexed TS. Default value is 1.

Program List: press the **<ENTER>-key** to enter 'Mux List' sub-menu. It shows all programs detected by JXDH-6002 II -X. The programs could be come from ASI input, Tuner, TS/IP input or the internal CI de-encryption block. Use **<▲> <▼>-keys** to roll up the program names, and use **<◀> <▶>-keys** to switch among input sources, where a number in front of the program name indicates the input source:

0-xxxxx displays the program name, which comes from ASI input.

1-xxxxx displays the program name, which comes from TUNER input.

2-xxxxx displays the program name, which comes from TS/IP input

3-xxxxx displays the program name which comes from the internal CI functional block.

On 'Mux List' sub-menu, on the first row, all encrypted programs are labeled with a '\$' sign. All programs that are being selected to be re-multiplexed are labeled as 'Pass', otherwise, the un-selected programs are labeled as 'Fobrid'. Use **<ENTER>-key** to selected or un-selected the program being shown.

When leaving the 'Mux List' sub-menu, a new menu will be shown '**Confirm changed?**' Press **<ENTER>-key** to validate all programs just be selected to be multiplexed or to scrap by pressing **<EXIT>-key**.

After a few seconds, the multiplexed TS will be generated and delivered to the specified destination(s).

Filter

Filter Switch: the internal filter could be switched On/Off. The default value is 'off'. To activate the filter function, you should turn on this filter functional block.

Bit Rate: should be set to a specified value that doesn't exceed the Maximum physical limit of the output medium, otherwise overflow occurs.

Source: Press the **<ENTER>-key** and use the **<▲> or <▼>-key** to roll up or down to select the signal source of filter function block, there are 4 type of signal source optional:

CI De-encrypted

TUNER

ASI Input

TS/IP input (only when the TS/IP is set "IP In", refer section 7.4.6 for more)

Use **<ENTER>-key** to save or press **<EXIT>-key** to scrap.

Program List: Press the **<ENTER>-key** to enter 'Filter List' sub-menu. It shows all programs carried by the signal come from the selected source in previous step. The programs could be come from ASI input, Tuner, TS/IP input or the internal CI de-encryption block. Use **<▲>** **<▼>-keys** to roll up the program names, where a number in front of the program name indicates the input source:

0-xxxxx displays the program name, which comes from ASI input.

1-xxxxx displays the program name, which comes from TUNER input.

2-xxxxx displays the program name, which comes from TS/IP input

3-xxxxx displays the program name which comes from the internal CI functional block.

On 'Filter List' sub-menu, all programs that are being selected to be filtered away are labeled as 'Forbid', otherwise, the un-selected programs are labeled as 'Pass'. Use **<ENTER>-key** to selected or un-selected the program being shown.

When leaving the 'Filter List' sub-menu, a new menu will be shown 'Confirm changed?' Press **<ENTER>-key** to validate all programs just be selected to be filtered away or to scrap by pressing **<EXIT>-key**.

After a few seconds, the filtered TS will be generated and delivered to the specified destination(s).

7.3.7 Ethernet

(Note this menu is showed only when the TS/IP streaming is installed and the board is set to "IP Out", refer to section 7.4.6 for how to set up.)

The TS/IP Ethernet connector could also be configured as the output of the transport stream over IP. The parameters listed below must be set to appropriate values for the network over which the transport stream over IP is broadcasted.

- **Stream IP Addr:** Enter the IP address for streaming IP output of the unit.

- **Stream Netmask:** Enter the network sub mask for the subnet to which the unit is connected for IP streaming traffic.

- **Stream Gateway:** Set the gateway for the network to which the unit is connected for IP streaming traffic.

- **Stream Mac Address:** factory-set MAC addresses are guaranteed to unique. Therefore you cannot configure the address.

- **Protocol:** select the protocol for multicast: UDP or RTP.

- **TS Pkts Per UDP:** set the number of the TS packages encapsulated in one UDP package. The valid range goes from 1 to 7.

- **Time To Live:** set the number of the routers over which the TS over IP can be transmitted.

The valid range goes from 1 to 5.

- **Type of Service:** select the type of service. There are: Normal, Min Monetary Cost, Max Reliability, Max Throughput or Min Delay optional.

- **Source:** select the source of the transport stream over IP streaming output. There are 4 type of source optional:

ASI Input

CI De-encrypted

TUNER

Mux TS (note the Mux TS is showed only when the Mux/Filter function block is enabled and turned on. The Mux TS indicates not only the after-multiplexed TS when Mux is enabled, but also the after-filtered TS when the filter is enabled, refer to section 7.3.6 and section 7.4.6 for how to set the Mux / Filter function block)

After the operation, the selected transport stream will be delivered to the TS / IP function block for further operation.

- **Mode:** select the mode of IP stream, you can select DVB or IPTV.

DVB mode: the transport stream which comes from the 'source' selected in previous step will be packed into IP Stream directly. Therefore the IP stream carries all programs and be delivered to the specified Multicast or Unicast IP address.

IPTV mode: the transport stream which comes from the 'source' selected in previous step will be de-Muxed to several single programs, and each program is packed into one IP stream. Therefore each IP stream carries only one program and be delivered to the specified Multicast or Unicast IP address. You can configure maximum 6 IPTV channels.

- **Multicast Setup:** use **<ENTER>-key** to enter sub-menu. The sub-menu is different according to different 'mode' selected in previous step.

DVB mode

- **Multicast IP:** Enter the IP address of the IP stream for the transport stream over IP output. You can configure the IP stream output mode in Multicast or Unicast.

Multicast could be established by setting Multicast IP address in the range of 239.255.255.255 to 224.0.0.0.

Unicast could be established with the same settings of Multicast, the only differences are the Multicast IP address, and should NOT be in the range of 224.0.0.0 to 239.255.255.255, which is for Multicast. Although the display is 'Multicast IP' on the first row, the stream itself is Unicast. The IP address of receiver device (maybe PC with VLC) needed to be set to as the unicast address on

JXDH-6002 II -X, please don't use DHCP to get a dynamic IP address for receiver device.

- **Multicast UDP Port:** Enter the UDP port number of the TS over IP stream output.

IPTV mode

- **Max Channels (<=6):** you can configure the number of IPTV channel. The valid range goes from 0 to 6.

After the configuration, you can use <▲> <▼>-keys to roll up and down between the channels. Each channel could be configured independently.

- **Channel x:** 'x' means the channel number. Press <ENTER>-key to go down to the sub-menu. There are 4 sub-menus:

x-Multicast IP: Enter the IP address of the IP stream for the transport stream over IP output.

You can also configure the IP stream output mode in Multicast or Unicast by setting Multicast IP address.

x-Multicast Port: Enter the UDP port number of the TS over IP stream output.

x-Switch: each channel could be switched On/Off independently. The default value is 'off'. To activate the channel, you should turn on.

x-Program: it shows all programs carried by the transport stream from the source selected. Press <ENTER>-key and use <▲> <▼>-keys to roll up and down between the program names, where a number in front of the program name indicates the input source:

0-xxxxx displays the program name, which signal source is ASI.

1-xxxxx displays the program name, which signal source is TUNER.

3-xxxxx displays the program name which comes from the internal CI functional block.

4-xxxxx displays the program name which comes from the internal Mux / Filter functional block.

All encrypted programs are labeled with a '\$' sign on the first row. Press <ENTER>-key to the program just be selected to be delivered to the specified IPTV channel or to scrap by pressing <EXIT>-key.

7.4 System

The system menu provides information about the general functions, the surroundings equipment and the hardware used.

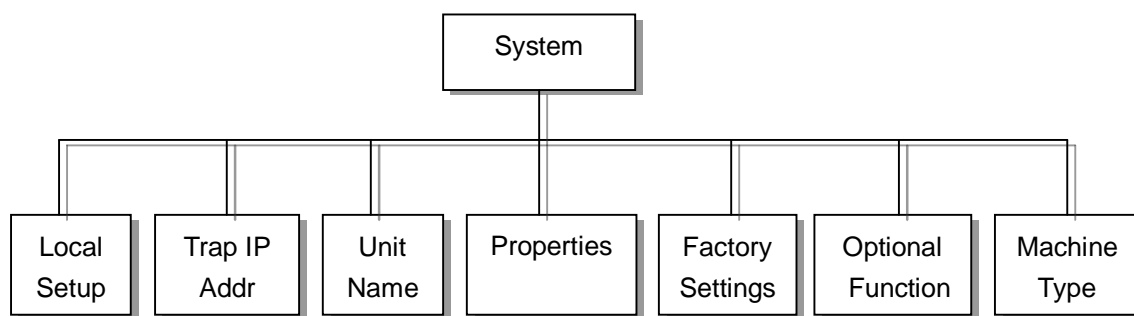

Figure 7.4 System Menu

7.4.1 Local Setup

Each JXDH-6002 II -X has an IP address, a network sub mask and a gateway. These must be set to an appropriate value for the network over which the unit can be accessed by the remote control system such as the HDMS.

- **IP Address:** The IP address for the unit.
- **Network Mask:** The network mask for the subnet to which the unit is connected.
- **Gateway:** The gateway for the network to which this unit is connected.

7.4.2 Trap IP Addr

The JXDH-6002 II -X provides a Monitor Center IP address. You can set this to be the same IP address of the Monitor Center, which is typically a PC in order to allow the device to send messages to the monitor center. If the JXDH-6002 II -X is connected with the HDMS remote management system, the Trap IP address is typically set to be the IP address of the PC on which the HDMS has been installed.

7.4.3 Unit Name

The JXDH-6002 II -X allows you to edit the unit name which is displayed on the front panel LCD. Default name is 'Digital TV Processor'. The unit name should not be longer than 20 characters in ASCII format.

7.4.4 Properties

You are allowed to check the properties information of the device.

- **MAC address:** Factory-set MAC address which is guaranteed to be unique. You cannot configure this address.
- **FW Version:** the version of the FPGA software (note this version number will changed automatically according to the TS/IP is configured as 'IP In' or 'IP Out').
- **SW Version:** the version of the main software.

7.4.5 Factory Settings

All the user configurable parameters will be set to the factory default settings, including IP address and the unit name. Note the unit will not be connected with the HDMS remote management system until the IP is properly configured.

7.4.6 Optional Function

This menu is protected by password, type in 900000 to the menu. There are two submenus:

- **External Board Type:** Press <ENTER>-key to active the menu, use <▲> <▼>-keys to configure the TS/IP functional block as 'IP In' or 'IP Out' or 'No Exist', and the option is exclusive. Press <ENTER>-key to confirm or to scrap by pressing <EXIT>-key.

After the operation, you need reboot the unit to valid the configuration.

IP In: the TS/IP port is configured as input, you can feed transport stream over IP into the unit. The menu 'Ethernet' will be showed under the inputs menu.

IP Out: the TS/IP port is configured as output, you can set the transport stream over IP output to the IP network. The menu 'Ethernet' will be showed under the outputs menu.

No Exist: the TS/IP port is invalid. Therefore the menu 'Ethernet' will not be showed anywhere.

- **Filter Function:** Press <ENTER>-key to active the menu, use <▲> <▼>-keys to configure the Mux/Filter functional block as 'Mux' or 'Filter' or 'Disable'. Press <ENTER>-key to confirm or to scrap by pressing <EXIT>-key.

7.4.7 Setting Machine Type

This setting is reserved for factory-setting, and you are not allowed to access this menu.

8. FAQ

1. Why is there nothing in the LCD?

Answer: Please check whether the power supply is connected well first. If not, insert it well and turn on the device. If there is still nothing displayed on the LCD, then the unit may be damaged, please contact the agent for technical support.

2. Why can the QPSK/QAM/COFDM/DVB-S2 signal not be locked?

Answer: Please ensure whether the input cable in connected well first. If not, insert it well. If it is connected well, please check whether all the necessary parameters are set properly. If not, please set the parameters properly. If the signal still cannot be locked, please check whether the quality of the signal is out of the threshold of the Tuner. If not, then the device might be damaged, please contact the agent for support.

3. Why can the ASI not be locked?

Answer: Please make sure the BNC cable is connected well and there are programs transmitted to the unit via the BNC cable.

4. Why can the JXDH-6002 II -X not be connected to HDMS?

Answer: Please ensure whether the Ethernet cable is connected well first. Make sure the parameters are set appropriately under "Local Setup". Check the whether HDSM software is installed correctly in PC which should be also set appropriately and can access the network the JXDH-6002 II -X connected.

9. Appendix

9.1 Accessory List

JXDH-6002 II -X	1pc
CD	1pc
User Manual	1pc
Power Cord	1pc
RCA A/V Cable	1pc
BNC Cable	1pc
XLR Connector	2pcs

9.2 Specification

QPSK Demodulation & FEC Parameters	
Input Frequency Range	C & Ku Band, 950~2150 MHz
Input Level	-25 dBm ~ -65 dBm
Input Impedance	75 Ω F type
Symbol Rate	2~45 Mb/s (SCPC or MCPC)
Rolling Off Factory	0.20 or 0.35
Punctured Rates	1/2, 2/3, 3/4, 5/6, 6/7, 7/8
Reeds Salomon Decoding	204, 188, T = 8 & I=12
DVB-C QAM Demodulation	
Connector	IEC, Female (7/8 MHz) or F Female (6 MHz) Input
Input Symbol Rate Range	1~7 Mbs (PAL), 1~6 Mbps (NTSC)
Demodulation	16/32/64/128/256 QAM
Tuner Bandwidth	6 MHz or 7 MHz or 8 MHz factory optional
FEC Decoder	1/2, 2/3, 3/4, 5/6, 7/8; K=7
Frequency Range	50~860 MHz

Digital Signal Input Level	-15~15 dBmV
Input Impedance	75 Ω F-type
DVB-T COFDM Demodulation	
Connector	IEC, Female (7/8 MHz) or F Female (6 MHz) Input
1 IF Loop through	Yes
Frequency Range	470-862 MHz, 174-230 MHz
Input Symbol Rate Range	4.98~31.67 Mbit/s (8 MHz bandwidth)
Constellation	QPSK, 16-QAM, 64-QAM
Tuner Bandwidth	8 MHz
Digital Signal Input Level	-20 to -75 dBmV
Input Impedance	75 Ω unbalanced
FFT mode	2K/8K
Guard Interval	1/4, 1/8, 1/16, 1/32, off
FEC Code Rate	1/2, 2/3, 3/4, 5/6 and 7/8
DS3 Input	
Input Impedance	75 Ω
Connector	BNC
Maximum Input Code Rate	44.736 Mbit/s
Format	Unframed Framing according to G.804/G.752 (DS3)
DS3 Loop Through Output	
Impedance	75 Ω
Maximum Output Code Rate	44.736 Mbit/s
Connector	BNC
Format	Unframed Framing according to G.804/G.752 (DS3)
TS over IP Output	
Connector	100 base-T RJ45
Output Bit Rate	70 Mbits/s Max.
UDP/RTP	Multicast or Unicast
Multicast Control Protocol	IGMPV2
I/O Interface on back panel	
LNB I/O	1×Input, 1×loop through output
RS-232	1×9-pin D-sub male
RJ45	1×Ethernet control port, 1×TS over IP output (factory optional)
ASI input	1
ASI output	2×Redundant output
SDI output	1 (optional)
RGB output	1×RCA
CVBS output	1×RCA, 1×BNC
Audio XRL Balance Output	1

General

Operating Temperature	0-45 °C
Storage Temperature	-20~70 °C
Humidity	<85%
Power Supply	AC 90V~260V 50Hz/60Hz
Dimensions	483 mm×255 mm×44 mm
Approximately Net Weight	4.2 kg

This document and the information contained in it is the property of Pro Broadband Inc. and may be the subject of patents pending and granted. It must not be used for commercial purposes nor copied, disclosed, reproduced, stored in a retrieval system or transmitted in any form or by any means (electronic, mechanical, photocopying, recording or otherwise), whether in whole or in part, without Pro Broadband Inc.'s prior written agreement.
© 2008 Pro Broadband Inc. All rights reserved.